

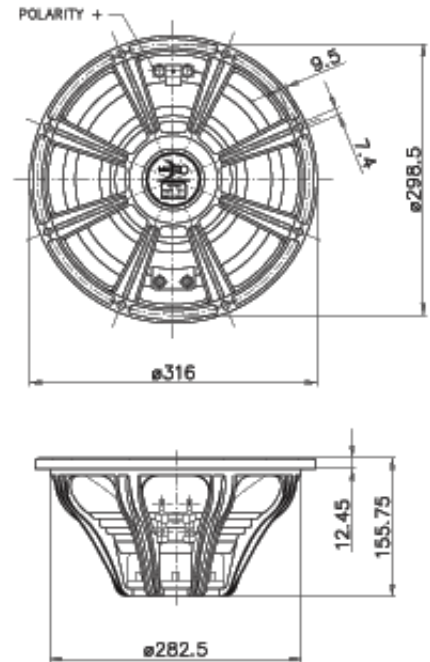

12FH520 Five Hundred Series



NOMINAL SPECIFICATIONS

Nominal Diameter	300 mm (12 in)
Overall Diameter	316 mm (12.44 in)
Bolt Circle Diameter	298.5 mm (11.75 in)
Baffle Cutout Diameter	284 mm (11.18 in)
Depth	155.75 mm (6.13 in)
Flange and Gasket Thickness	12.5 mm (0.49 in)
Net Weight	4 Kg (8.8 lb)
Shipping Box (Single Carton Box)	350x350x200 mm (13.8x13.8x7.9 in)
Shipping Weight	4.6 Kg (10.1 lb)

ELECTRICAL SPECIFICATION

Nominal Impedance	8 Ohm
Minimum Impedance	6.3 Ohm
AES Power Handling *	600 W
Maximum Power Handling **	1200 W
Sensitivity (1W/1m)	98 dB
Frequency Range	50÷4000 Hz
Voice Coil Diameter	77 mm (3 in)
Winding Material	Al
Former Material	Glass Fiber
Winding Depth	18 mm (0.71 in)
Magnetic Gap Depth	12 mm (0.47 in)
Flux Density	1.1 T
Magnet	Neodymium Slug
Demodulation	Aluminum Ring
Suspension ***	Triple Roll

THIELE & SMALL PARAMETERS

Fs	50 Hz
Re	5.1 Ohm
Qes	0.3
Qms	11.1
Qts	0.29
Vas	64.2 dm ³ (2.27 ft ³)
Sd	500 cm ² (77.5 in ²)
Xmax ****	7 mm
Xdamage *****	19.5 mm
Mms	56 g
Bl	17.3 N/A
Le	0.74 mH
Mmd	49.7 g
Cms	0.18 mm/N
Rms	1.58 Kg/s
Eta Zero	2.6 %
EBP	167 Hz

NOTES

Spider Profile: 1x variable height waves

(*) 2 Hours Test According to AES 2-1984 Rev. 2003

(**) Maximum power is defined as 3dB greater than nominal power.

(***) Treated Polycotton

(****) $X_{max} = [(winding\ depth - magnetic\ gap\ depth) / 2] + (magnetic\ gap\ depth / 3)$

(*****) Maximum excursion before permanent damage

CURVES

