

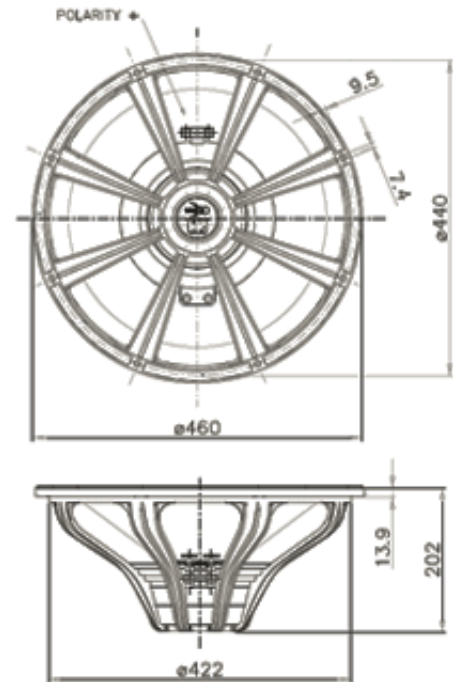

18HP1020 High Performance Series



NOMINAL SPECIFICATIONS

Nominal Diameter	460 mm (18 in)
Overall Diameter	460 mm (18.11 in)
Bolt Circle Diameter	440 mm (17.32 in)
Baffle Cutout Diameter	422 mm (16.61 in)
Depth	202 mm (7.95 in)
Flange and Gasket Thickness	13.9 mm (0.55 in)
Net Weight	6.1 Kg (13.4 lb)
Shipping Box (Single Carton Box)	536x536x293 mm (21.1x21.1x11.5 in)
Shipping Weight	7.4 Kg (16.3 lb)

ELECTRICAL SPECIFICATION

Minimum Impedance	6.6 Ohm
Nominal Impedance	8 Ohm
AES Power Handling *	1000 W
Maximum Power Handling **	2000 W
Sensitivity (1W/1m)	99 dB
Frequency Range	35÷1600 Hz
Voice Coil Diameter	100 mm (4 in)
Winding Material	Cu
Former Material	Glass Fiber
Winding Depth	23 mm (0.9 in)
Magnetic Gap Depth	12 mm (0.47 in)
Flux Density	1.3 T
Magnet	Neodymium Slug
Demodulation	No
Suspension ***	Triple Roll

THIELE & SMALL PARAMETERS

Fs	35 Hz
Re	5.4 Ohm
Bl	28 N/A
Mms	182 g
Cms	0.11 mm/N
Rms	4.1 Kg/s
Qes	0.28
Qms	9.74
Qts	0.27
Vas	207.2 dm ³ (7.32 ft ³)
Sd	1134 cm ² (175.8 in ²)
Xmax ****	9.5 mm
Xdamage *****	17.5 mm
Le	1.7 mH
Mmd	159.5 g
Eta Zero	3.1 %
EBP	125 Hz

NOTES

Spider Profile: 2x non-adjacent symmetrical constant height waves

(*) 2 Hours Test According to AES 2-1984 Rev. 2003

(**) Maximum power is defined as 3dB greater than nominal power.

(***) Treated Polycotton

(****) $X_{max} = [(winding\ depth - magnetic\ gap\ depth) / 2] + (magnetic\ gap\ depth / 3)$

(*****) Maximum excursion before permanent damage

CURVES

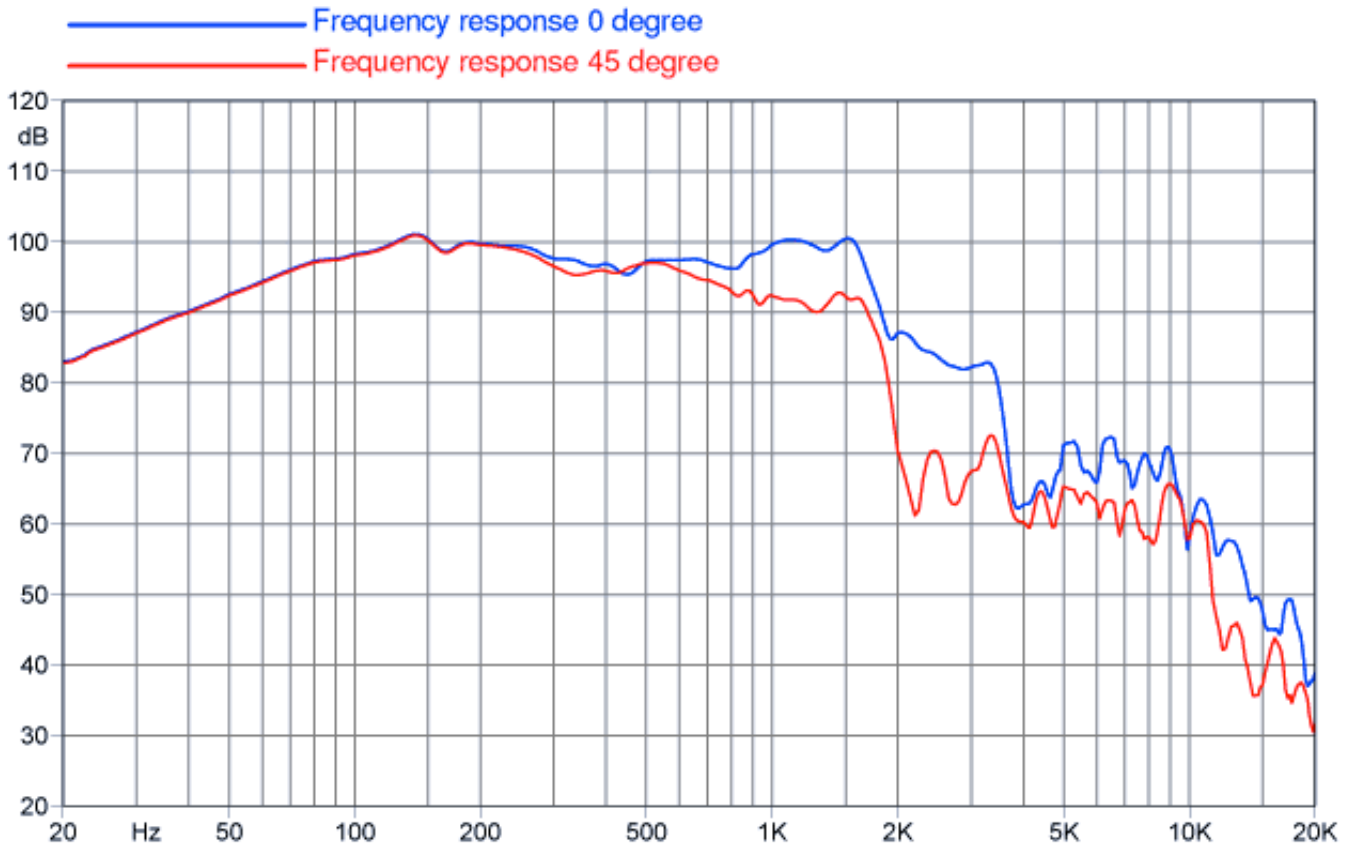

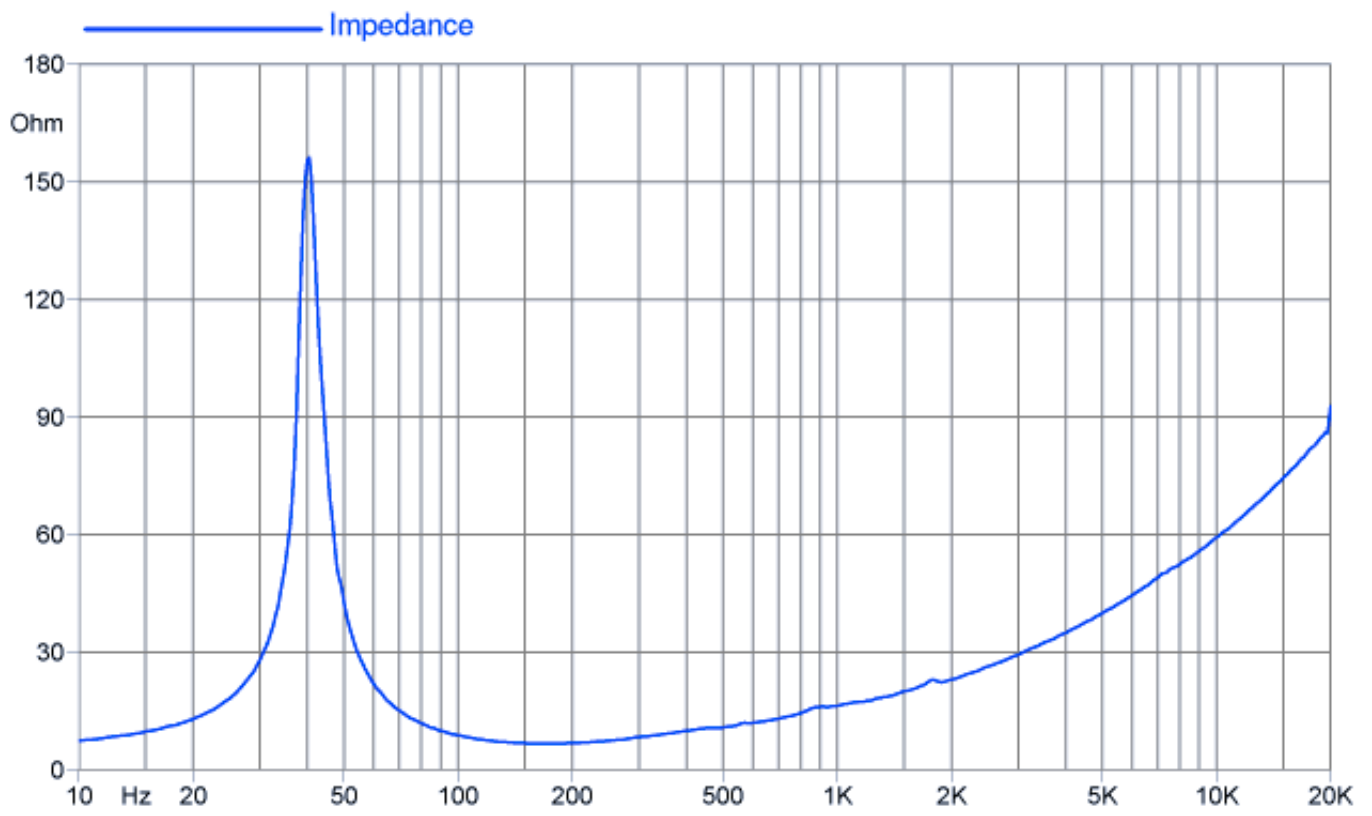

©Copyright 2012 - Faital S.p.A. Fabbrica Italiana Altoparlanti - All right reserved.