

# 5MDN38

**16Ω****LF Drivers - 5.0 Inches**

- 200 W continuous program power capacity
- 38 mm (1.5 in) aluminium voice coil
- 230 - 10000 Hz response
- 96 dB sensitivity
- Shorting copper cap for extended HF response

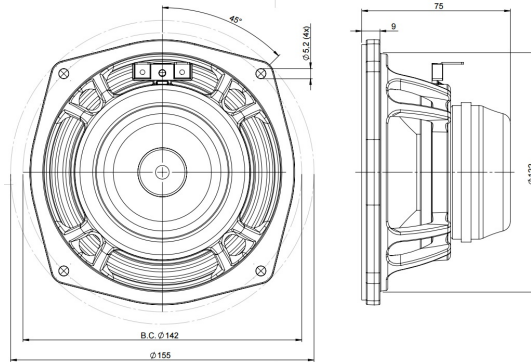

# 5MDN38

## LF Drivers- 5.0 Inches

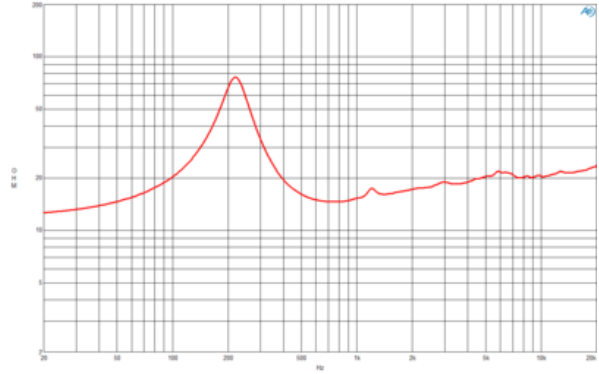
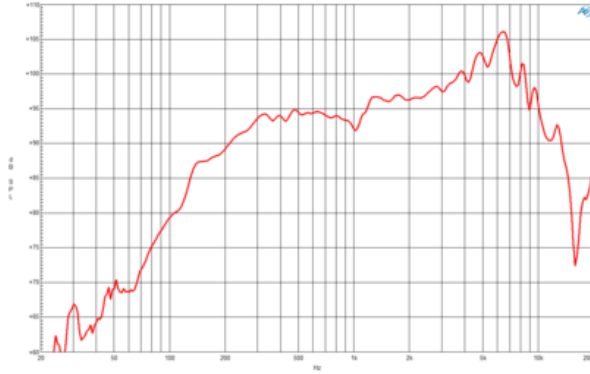

### SPECIFICATIONS

Nominal Diameter	127 mm (5.0 in)
Nominal Impedance	16 $\Omega$
Minimum Impedance	14.5 $\Omega$
Nominal Power Handling <sup>1</sup>	100 W
Continuous Power Handling <sup>2</sup>	200 W
Sensitivity <sup>3</sup>	96.0 dB
Frequency Range	230 - 10000 Hz
Voice Coil Diameter	38 mm (1.5 in)
Winding Material	Aluminium
Former Material	Glass Fibre
Winding Depth	10.0 mm (0.39 in)
Magnetic Gap Depth	6.0 mm (0.24 in)
Flux Density	1.25 T

### DESIGN

Surround Shape	Triple Roll
Cone Shape	Exponential
Magnet Material	Neodymium Ring
Spider	Single
Pole Design	Straight Pole
Woofer Cone Treatment	WP Waterproof Front Side

### PARAMETERS<sup>4</sup>

Resonance Frequency	230 Hz
Re	11.7 $\Omega$
Qes	0.57
Qms	3.0
Qts	0.48
Vas	0.8 dm <sup>3</sup> (0.03 ft <sup>3</sup> )
Sd	95.0 cm <sup>2</sup> (14.7 in <sup>2</sup> )
$\eta_0$	1.7 %
Xmax	3.5 mm
Maximum Excursion	2.5 mm
Mms	8.0 g
Bl	15.0 Txm
Le	0.7 mH
EBP	403 Hz

### MOUNTING AND SHIPPING INFO

Overall Diameter	155 mm (6.1 in)
Bolt Circle Diameter	142 mm (5.6 in)
Baffle Cutout Diameter	122.0 mm (4.8 in)
Depth	75 mm (2.95 in)
Flange and Gasket Thickness	9 mm (0.35 in)
Air Volume Occupied by Driver	0.35 dm <sup>3</sup> (0.01 ft <sup>3</sup> )
Net Weight	0.85 kg (1.9 lb)
Shipping Units	1
Shipping Weight	1.05 kg (2.31 lb)
Shipping Box	210x210x125 mm (8.27x8.27x4.92 in)

### SERVICE KIT

RCK005MDN3816

1. 2 hours test made with continuous pink noise signal within the range Fs-10Fs. Power calculated on rated nominal impedance. Loudspeaker in free air.
2. Power on Continuous Program is defined as 3 dB greater than the Nominal rating.
3. Applied RMS Voltage is set to 4V for 16 ohm Nominal Impedance
4. Thiele-Small parameters are measured after a high level 20 Hz sine wave preconditioning test.